

NSD1095N

Neodymium High Frequency Driver

Key Features

- 110 dB SPL 1W / 1m average sensitivity
- 1 inch exit throat
- 1,75 inch voice coil diameter
- 100W continuous program power handling
- True Piston Motion (TPM) Technology
- Excellent thermal exchange
- Neodymium ring magnetic structure
- Patented phase plug design



General Description

The NSD1095N has been designed for situations where the highest quality is required. With a 1-inch exit throat, it has been developed to match the XT1086 constant directivity horn.

Equipped with unique Phase Plug architecture (Patent n. WO 2004/040942), the NSD1095N has been designed to give high level manufacturing consistency and a smooth coherent wavefront at the horn entrance across the whole working frequency range. The phase plug short openings and high flare rate value assure low distortion and overall, the phase plug demonstrates remarkable improvements in mid-high frequency reproduction.

A further innovation in the NSD1095N, when compared to excellent performances of the ND1090, is a titanium material treatment (TPM technology) developed after extensive research by Eighteen Sound. The special titanium nitride coated dome dramatically improves stiffness with obvious benefits in transient and intermodulation distortion response. With its very high value of elasticity modulus, (six times higher than titanium and two times higher than beryllium), the nitride thin film is capable of doubling the diaphragm overall stiffness. The piston frequency range motion extends frequency by 25%, showing a predictable, ideal frequency response decay and avoiding top-end spurious resonances.

The NSD1095N diaphragm assembly is composed of nitride titanium dome sandwiched to a proprietary treated polyester suspension. This design maintains low resonance and lowers the minimum crossover point value to 1.6kHz. An edge-wound copper-clad aluminum voice coil, wound on proprietary treated Nomex, completes the diaphragm assembly. Nomex shows a 30% higher value of tensile elongation at a working operative temperature (200°C) when compared to Kapton. Moreover, this proprietary former material is also suitable for use in high moisture content environments.

The NSD1095N's powerful neodymium magnet assembly has been designed to obtain 20KGauss in the gap giving major benefits in transient response. A copper ring on the pole piece reduces inductance above 10 kHz, improving phase and impedance linearization. The custom designed O-ring creates a tight seal between the plate and the cover assuring air chamber loading. Excellent heat dissipation and thermal exchange are guaranteed by the direct contact between the magnetic structure and the aluminum cover which leads to a lower power compression value.

Due to the increase in use of high power audio systems at outdoor events or in marine environments, the ability to perform properly under inclement weather conditions is a key feature of the Eighteen Sound philosophy. Hence, in addition, a special treatment has been applied to the magnet and the top and back plates of the magnetic structure making the driver more resistant to the corrosive effects of salts and oxidization. This treatment is more effective than any other treatment used by other manufacturers.

0421T8N410

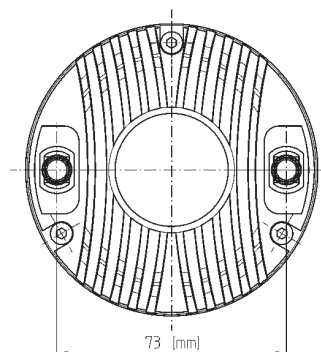
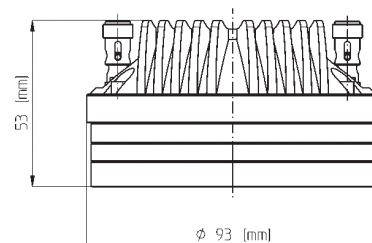
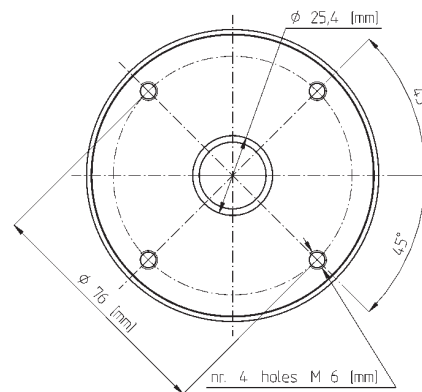

NEODYMIUM HF DRIVERS

info@eighteensound.com
www.eighteensound.com



NSD1095N

Neodymium High Frequency Driver

GENERAL SPECIFICATIONS

THROAT DIAMETER	25,4 mm (1 in)
RATED IMPEDANCE	8 ohm
DC RESISTANCE	5,3 Ohm
MINIMUM IMPEDANCE	7 Ohm at 4000Hz
LE (AT 1KHZ)	67 µH
POWER HANDLING	
CONTINUOUS PINK NOISE (1)	50W above 1,6 kHz
CONTINUOUS PROGRAM (2)	100W above 1,6 kHz
SENSITIVITY(1W@1M) (3)	110 dB
FREQUENCY RANGE	1600Hz ÷ 20kHz
RECOMM. XOVER FREQUENCY	1600Hz (12dB/oct slope)
DIAPHRAGM MATERIAL	Polyethylene - Treated Titanium
VOICE COIL DIAMETER	44,4mm (1 3/4 in)
VOICE COIL WINDING MATERIAL	Edge-wound aluminum
MAGNET MATERIAL	Neodymium
FLUX DENSITY	2 T
BL FACTOR	9,1 N/A
POLARITY	Positive voltage on “+” terminal gives positive pressure in the throat

MOUNTING INFORMATIONS

Overall diameter	93 mm (3,7 in)
Mounting holes diameter	4 M6 holes 90° at Ø 76 mm (3 in)
Bolt circle diameter	76 mm (3 in)
Total depth	53 mm (2,1 in)
Net weight	1,2 Kg (2,6 lb)
Shipping weight	1,3 Kg (2,9 lb)
CardBoard Packaging dimensions	97x97x58 mm (3,8x3,8x2,3 in)

NSD1095N MEASURED WITH 1W INPUT ON RATED IMPEDANCE AT 1M DISTANCE ON XT1086 HORN MOUTH AXIS

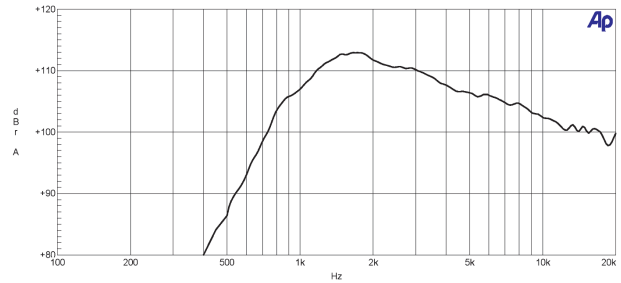

FREE AIR IMPEDANCE MAGNITUDE CURVE

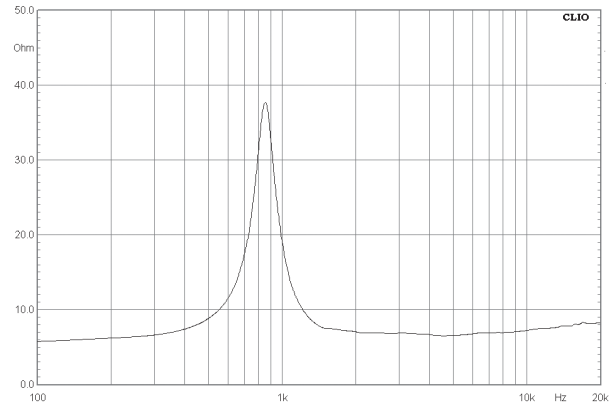

NOTES

- (1) Continuous pink noise power rating is tested with a pink noise input having a 6 dB crestfactor for two hours duration within the specified range. Power calculated on rated impedance.
- (2) Program Power is defined as 3 dB greater than continuous pink noise but with 50% dutycycle.
- (3) Sensitivity is measured at 1W input on rated impedance at 1m on axis from the mouth of XT1086 averaged between 1 kHz and 4 kHz.

Eighteen Sound engages in research and product improvement. New materials and design refinements can be introduced into existing products without notice.